

Reference Guide

Model: EB7NE

The EB7NE is a non-enclosed version of the Magma 7 Slot PCI Express® to PCI Express® product. Non-enclosed board-sets are intended for OEMs and System Integrators who wish to utilize a non-Magma enclosure. In addition, the EB7NE may also be a solution for current Magma product owners who want to install a new Magma backplane into their existing Magma enclosure.

This document is intended to provide a brief overview of connectors, dimensions, and pin outs. When installing and using your Magma product, please refer to the EB7 User's Manual Document No. 09-09915-01 that you can access at Magma website <http://magma.com/> for detailed information on connecting, using, and troubleshooting. When integrating the chassis with the Host Computer, please refer to the EB7 Quick Install Guide that you can also access at Magma website <http://magma.com/>

Contents

GENERAL SPECIFICATIONS	3
PRE-INSTALLATION INFORMATION	3
PARTS LIST	4
OUT OF BOX CONNECTION	7
SYSTEM INTEGRATION	7
UPGRADES	9
BACKPLANE INSTALLATION	10
"HOT-SWAPPABLE" PCIE CARDS	10
COMPLIANCE INFORMATION	10

General Specifications

The Magma 7 Slot PCI Express® to PCIE Express® Expansion System (Model EB7NE) is a general-purpose bus expansion chassis for the Peripheral Component Interconnect Express (PCIe) local bus. The expansion chassis is fully compliant with the PCI Express Local Bus Specification 1.1. This system consists of a PCI Express host card, a 1-meter iPass cable, a 7 slot PCIe expansion backplane and a power cord.

Item	Description
§ Host Card:	Low Profile PCI Express x8 (8 lane)
§ Backplane:	7 PCIe slots
§ Enclosure:	4U Black Rack-mount (All Steel)
§ Dimensions:	19" W x 7" H x 17.7" D
§ Weight:	24 lb or 11.804 kg
§ Standard Cable Length:	1-meter iPass cable
§ PCI Express Bus Specification	Revision 1.1
§ PCI Express Local Bus Specification:	Revision 2.3
§ PCIE Bridge Architecture Spec:	Revision 1.2
§ Interconnect Bandwidth:	2000 MB/sec or 2 GB/sec or 20 Gbps
§ Cooling:	One 85.2 CFM fan One fan in power supply
§ MTBF:	53,000 hours
§ Operating Environment:	0° to 50° C Operating Temperature -20° to 60° C Storage Temperature 5% to 85% Relative Humidity, Non-condensing
§ Operating Systems:	Windows XP/2000/Server 2003/Vista Mac OS X version 10.4.x + Red Hat Linux 9 Solaris
§ Warranty:	1 Year Return to Factory
§ Available Options:	§ 3-meter cable (PN: SUBCBL3IP) § Disk Drive Cage for up to seven 3.5" internal disk drives (PN: RDRIVECAGE) § PCIe card hold down kit (PN: RCHD7) § Rack-mount slide kit (PN: RSLIDES-XX)

Pre-Installation Information

Before using the Magma expansion chassis you should perform the following steps:

- Inventory the shipping carton contents for all of the required parts
- Gather all of the necessary tools required for installation
- Read this manual

Parts List

Qty	Item	Purpose
1	PCI Express Host Card (Low-profile) 3	Installed in available x8+ PCIe slot in host computer. Provides connection point from computer to backplane.
1	7 slot PCI Express backplane 1	Provides seven PCIe slots
2	1-meter cables 2	Connects host card to backplane.
1	Low profile mounting bracket	For mounting host card in low profile cases.
1	ATX core plate	Provides I/O shield for the x1 and x3 connectors when EB7NE is installed in an ATX style enclosure.
1	Slot cover	Slot cover for non-operational PCIE slot on backplane.
1	Power Supply Load Resistor	When connected to power supply power tab, provides required minimum 5 volt load for the power supply to regulate power properly. Required for 3.3 volt PCIe card configurations only.
1	EB7NE User's Manual	Guide for connection, verification and troubleshooting.

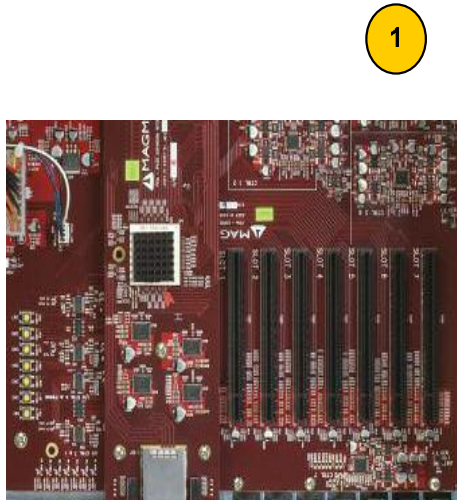
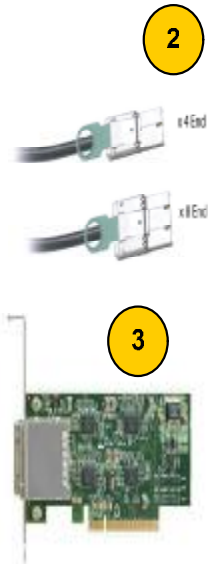

The following steps will guide you through the installation of your Magma expansion system.

Electrostatic Discharge (ESD) Warning



All PCIe cards are susceptible to electrostatic discharge. When moving PCIe cards, it is best to carry the cards in anti-static packaging. If you need to set a PCIe card down, be sure to place it inside or on top of an anti-static surface. For more information, see [“Protecting Against Electrostatic Discharge”](#) in the Preface.

WARNING



High voltages are present inside the expansion chassis when the unit’s power cord is plugged into an electrical outlet. Disconnect the power cord from its source before removing the enclosure cover. Turning the system power off at the power on/off switch does not remove power to components. High voltage is still present.

CAUTION



Before touching anything inside the enclosure, move to an ESD station and follow proper ESD procedures. Failure to do so may result in electrostatic discharge, damaging the computer or its components. For more information, see [“Protecting Against Electrostatic Discharge”](#) in the Preface.

STOP



If your Magma expansion chassis was not purchased directly from Magma, you must check to ensure that it doesn’t contain any pre-installed PCIe cards.

Check the rear side of the chassis to see if any PCIe cards are visible in the slots. If you see a PCIe card, you should continue installation using instructions provided by your dealer.



DANGER

The **Power Supply Load Resistor** will be *hot* to the touch immediately after connected to a power supply power tab. Use caution when touching the Load Resistor after it has been installed.



IMPORTANT

It is expected that the user will provide their own power supply to meet the requirements of the PCIe cards to be installed in the backplane. For best results, a minimum 400W power supply with (2) ATX connectors is recommended. For convenience, compatible power supplies are available from Magma.



IMPORTANT

The user should supply a power switch compatible with their non-Magma enclosure. The Magma expansion product must be turned on before the host computer for proper configuration. For this reason, a Push-on/Push-off switch is required. A momentary switch will not work with this product.

Out of Box Connection

Please refer to the [EB7 User's Manual](#) for complete connection and verification instructions.

Electrostatic Discharge (ESD) Warning



Electrostatic Discharge (ESD) is the enemy of semiconductor devices. You should always take precautions to eliminate any electrostatic charge from your body and clothing before touching any semiconductor device or card by using an electrostatic wrist strap and/or rubber mat.

System Integration

The picture below shows the backplane shipped to you and shows some of the connectors.



The diagram below depicts the backplane and shows the connectors involved in connecting the backplane to other resources of the system.

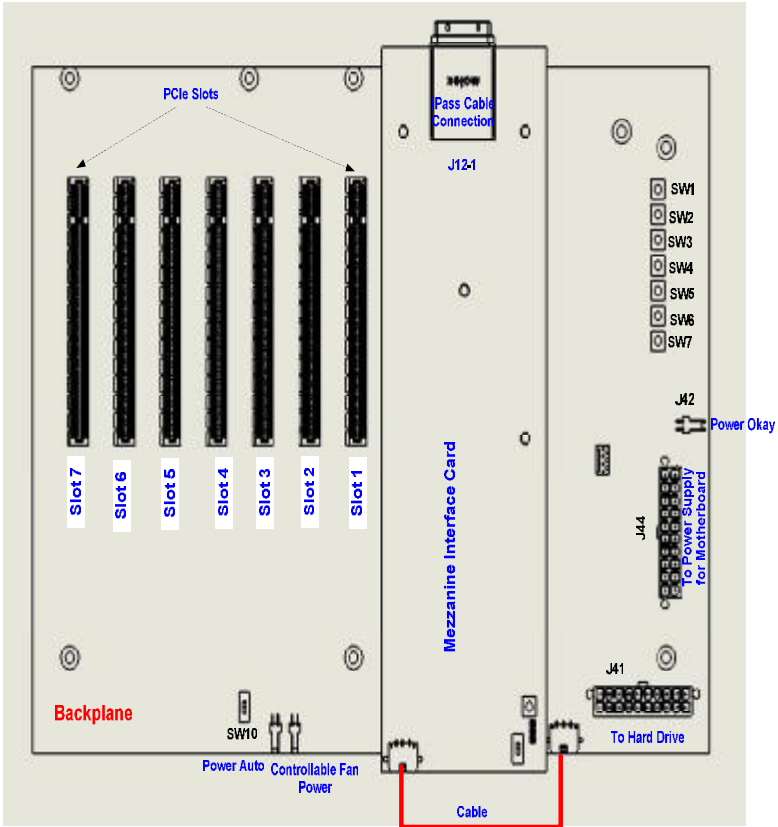

The 1-meter iPass cable included with your Magma expansion chassis features a x4 connector on one side and a x8 connector on the other.

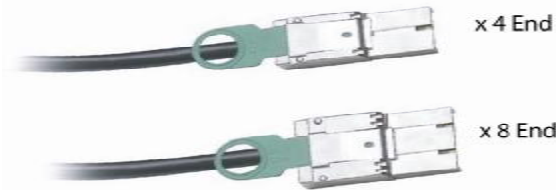

Carefully position the backplane so that the supplied expansion cable will conveniently reach from the host computer to the connectors on the back of the chassis. Then connect the x8 end of the cable to the host card and the x4 end of the cable to the expansion chassis.



Connect x4 end to the backplane



Connect x8 end to the host card.

Upgrades

The illustration below depicts the installation of the EB7NE in a Magma chassis. Use this illustration as a guide when installing the EB7NE in your Magma enclosure.

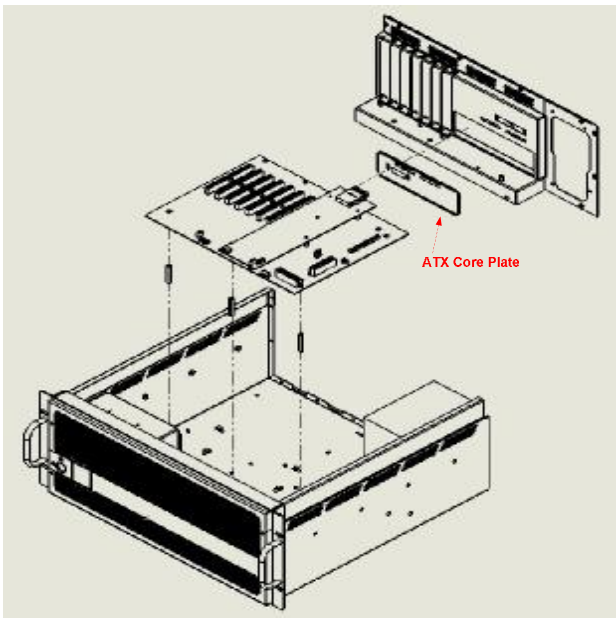

Backplane installation

Shut down your Magma expansion system. Remove the cover and PCIE cards. Unplug all cables and wires attached to backplane. To make reconnection simple, make note of where cables and wires are connected to original backplane, i.e. power supply, fans, power LED. Remove the mounting screws and lift the original backplane out of the chassis.

Place the new backplane into the enclosure by aligning the iPass connectors with the cut-outs on the back panel. Align the seven mounting holes on the backplane with the seven stand-offs and secure with screws. Loosely attach the screws until you are sure the backplane is installed and adjusted in its proper place before tightening. Reconnect cables and wires as shown below:



IMPORTANT

Connect Power Supply Load Resistor to a power tab attached to the power supply



DANGER

The **Power Supply Load Resistor** will be *hot* to the touch immediately after connected to a power supply power tab. Use caution when touching the Load Resistor after it has been installed.



“Hot-Swappable” PCIe Cards

New technology allows you to remove your 3rd Party PCIe cards for maintenance or replacement – without shutting the system down. Each of the four PCIe slots is controlled by a Hot Button as seen below:

Simply press the button corresponding to the slot you wish to “power-down,” hold the button for a minimum of five (5) seconds and then release it. The power has now been removed from that slot. All other PCIe cards remain fully functional, as they are independent of this slot.

Compliance Information

These devices have been tested and found to comply with FCC and CE EMC requirements in Magma chassis. All components used in the product are RoHS compliant. This does not ensure that non-Magma products will comply with EMC requirements with these devices installed. It is the responsibility of the integrator to ensure that their products are compliant with all regulations where their product will be used.

Magma

PCIE Expansion Products

9918 Via Pasar, San Diego, CA 92126, USA

Phone (858) 530-2511 • Fax (858) 530-2733

Email: support@magma.com

www.magma.com

MANUAL PN 09-09921-00-A